

ZETA

4680TOP160P63

EAN 4031582307863

Swivel castor, housing made of very heavy pressed steel, reinforced, bright zinc plated, blue passivated, sealed swivel double ball bearing, reinforced and heat-treated ball covers, riveted king pin, dust ring with integrated grease nipple, wheel axle with nut, plate fitting. Wheel centre made of Polyamide, heavy duty, precision ball bearing



BETTER MOBILITY. BETTER LIFE.



Picture may differ from original product

Technical Data

Wheel diameter	160 mm
Wheel width	50 mm
Castor width	96 mm
Size of Plate	137 x 105 mm
Plate hole centres	105 x 80/75 mm
Plate hole	11 mm
Dome-Ø	96 mm
Offset	55 mm
Swivel Interference	270 mm
Overall height	200 mm
Temperature	- 30 / + 80 °C
Standard	EN 12532
Weight	3.274 kg
Swivel Radius	135 mm
Hardness of tread	Shore D 75
Load capacity	800 kg
Load capacity (static)	1600 kg

Dimensions

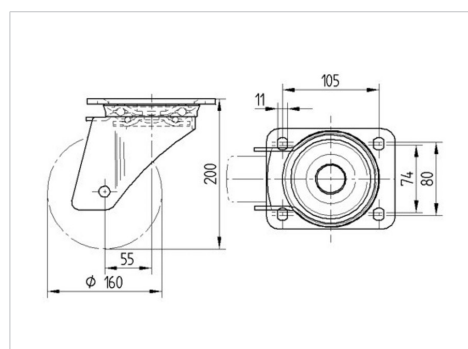

Structure & Mounting

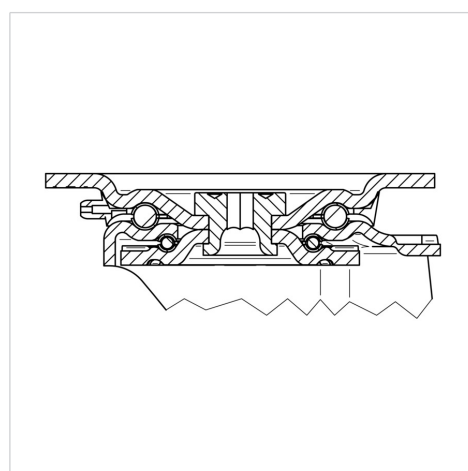

Advantages at a glance

Roll performance	● ● ● ● ●
Movement noise	● ○ ○ ○ ○
Attrition	● ● ● ● ●
Corrosion resistance	● ● ● ○ ○

ZETA

4680TOP160P63

EAN 4031582307863



BETTER MOBILITY. BETTER LIFE.

Structure & Mounting

