

# ALPHA

3477IEP160P63

EAN 4031582374216

Swivel castor with total lock, tail end of castor, housing made of pressed steel, bright zinc plated, blue passivated, double ball bearing swivel head, wheel axle with nut, dustguard, plate fitting. Wheel centre made of Aluminium, Tread: black elastic-tyre, vulcanized, precision ball bearing



BETTER MOBILITY. BETTER LIFE.



Picture may differ from original product

## Technical Data

Wheel diameter	160 mm
Wheel width	50 mm
Castor width	96 mm
Size of Plate	137 x 105 mm
Plate hole centres	105 x 80/75 mm
Plate hole	11 mm
Dome-Ø	96 mm
Offset	60 mm
Swivel Interference	334 mm
Overall height	200 mm
Temperature	- 20 / + 85 °C
Standard	EN 12532
Weight	3.039 kg
Swivel Radius	167 mm
Hardness of tread	Shore A 68
Load capacity	350 kg
Load capacity (static)	700 kg

## Advantages at a glance

Roll performance	● ● ● ○ ○
Movement noise	● ● ● ○ ○
Attrition	● ● ● ○ ○
Corrosion resistance	● ● ● ○ ○

## Dimensions

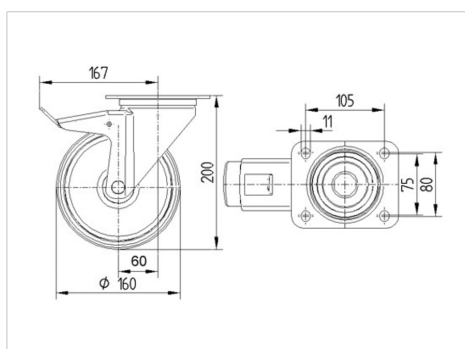

## Structure & Mounting



# ALPHA

3477IEP160P63

EAN 4031582374216



BETTER MOBILITY. BETTER LIFE.

## Structure & Mounting

