

# AGILA

2470PJO125P30-13

EAN 4031582334937

Swivel castor, housing made of pressed steel, bright zinc plated, blue passivated, double ball bearing swivel head, wheel axle with nut, bolt hole. Wheel centre made of Polypropylene, Tread: TENTEprene (thermoplastic rubber), grey non-marking, plain bearing. Castors can be mounted with standard screws; various length screws can be used.



BETTER MOBILITY. BETTER LIFE.



Picture may differ from original product

## Technical Data

Wheel diameter	125 mm
Wheel width	32 mm
Castor width	60 mm
Centre hole	13 mm
Dome-Ø	60 mm
Offset	41 mm
Swivel Interference	207 mm
Overall height	160 mm
Temperature	- 20 / + 60 °C
Standard	EN 12530
Weight	0.636 kg
Swivel Radius	103.5 mm
Hardness of tread	Shore A 87
Load capacity	100 kg
Load capacity (static)	200 kg

## Structure & Mounting

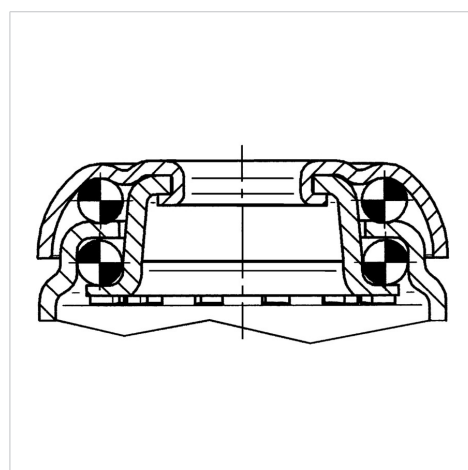

## Advantages at a glance

Roll performance	● ● ● ○ ○
Movement noise	● ● ● ○ ○
Attrition	● ● ● ○ ○
Corrosion resistance	● ● ● ○ ○