

LUMINA

A525POI050L51-8

EAN 4031582317428

Swivel castor with wheel brake, housing made of Polypropylene, with blind hole fitting. Wheel centre made of Polypropylene, plain bearing



BETTER MOBILITY. BETTER LIFE.



Picture may differ from original product

Technical Data

Wheel diameter	50 mm
Width of Tread	7 mm
Castor width	54 mm
Centre hole	8 mm
Offset	20 mm
Swivel Interference	124 mm
Overall height	56 mm
Temperature	- 20 / + 60 °C
Standard	EN 12528
Weight	0.056 kg
Swivel Radius	62 mm
Hardness of tread	Shore D 65
Load capacity	40 kg
Load capacity (static)	80 kg

Structure & Mounting

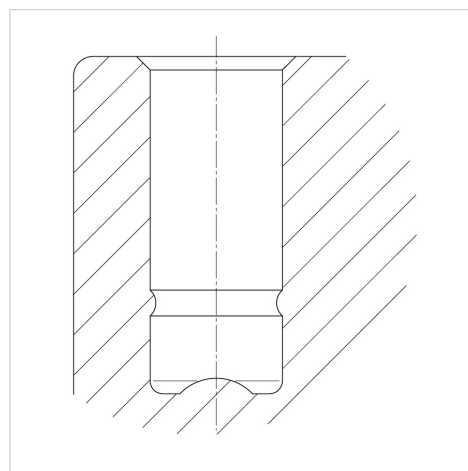

Advantages at a glance

Roll performance	● ● ● ○ ○
Movement noise	● ● ● ○ ○
Attrition	● ● ● ○ ○
Corrosion resistance	● ● ● ○ ○