

LINEA

5920UAP065L51-10 RaI 9002

EAN 4031582437065

Swivel castor, housing made of Polyamide, with blind hole fitting. Wheel centre made of Polyamide, Tread: Polyurethane, precision ball bearing



BETTER MOBILITY. BETTER LIFE.



Picture may differ from original product

Technical Data

| | |
|------------------------|----------------|
| Wheel diameter | 65 mm |
| Width of Tread | 13.9 mm |
| Castor width | 46 mm |
| Centre hole | 10 mm |
| Dome-Ø | 23 mm |
| Swivel Interference | 112 mm |
| Overall height | 68 mm |
| Temperature | - 10 / + 40 °C |
| Standard | EN 12530 |
| Weight | 0.118 kg |
| Swivel Radius | 56 mm |
| Hardness of tread | Shore A 87 |
| Load capacity | 90 kg |
| Load capacity (static) | 180 kg |

Advantages at a glance

| | |
|----------------------|-----------|
| Roll performance | ● ● ● ● ● |
| Movement noise | ● ● ● ● ○ |
| Attrition | ● ● ● ● ● |
| Corrosion resistance | ● ● ● ● ○ |

Dimensions

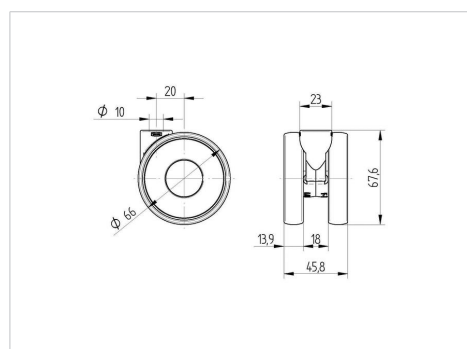

Structure & Mounting

