

LEVINA

5370PJP100P30-13

EAN 4031582347425

Swivel castor, housing and wheels made from high grade synthetic materials, double ball bearing swivel head, bolt hole. Wheel centre made of Polypropylene, Tread: TENTEprene (thermoplastic rubber), grey non-marking, precision ball bearing



BETTER MOBILITY. BETTER LIFE.



Picture may differ from original product

Technical Data

Wheel diameter	100 mm
Width of Tread	32 mm
Castor width	59 mm
Centre hole	13 mm
Dome-Ø	59 mm
Offset	36 mm
Swivel Interference	172 mm
Overall height	137 mm
Temperature	- 10 / + 40 °C
Standard	EN 12530
Weight	0.422 kg
Swivel Radius	86 mm
Hardness of tread	Shore A 87
Load capacity	100 kg
Load capacity (static)	200 kg

Advantages at a glance

Roll performance	● ● ● ○ ○
Movement noise	● ● ● ● ○
Attrition	● ● ● ○ ○
Corrosion resistance	● ● ● ● ○

Dimensions

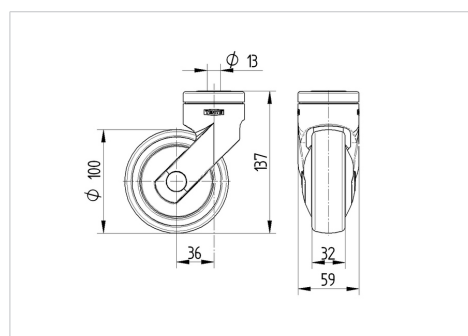

Structure & Mounting

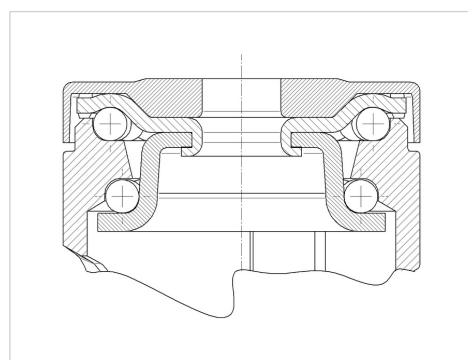

LEVINA

5370PJP100P30-13

EAN 4031582347425



BETTER MOBILITY. BETTER LIFE.

Structure & Mounting

