

AGILA TWIN

2977PJO075P30-10

EAN 4031582302912

Swivel castor with total lock, tail end of castor, housing made of pressed steel, bright zinc plated, blue passivated, double ball bearing swivel head, wheel axle with nut, bolt hole. Wheel centre made of Polypropylene, Tread: TENTEprene (thermoplastic rubber), grey non-marking, plain bearing



BETTER MOBILITY. BETTER LIFE.



Picture may differ from original product

Technical Data

Wheel diameter	75 mm
Width of Tread	25 mm
Castor width	71 mm
Centre hole	10,3 mm
Dome-Ø	65 mm
Offset	31.3 mm
Swivel Interference	198 mm
Overall height	99 mm
Temperature	- 20 / + 60 °C
Standard	EN 12530
Weight	0.587 kg
Swivel Radius	99 mm
Hardness of tread	Shore A 87
Load capacity	100 kg
Load capacity (static)	200 kg

Advantages at a glance

Roll performance	● ● ● ○ ○
Movement noise	● ● ● ○ ○
Attrition	● ● ● ○ ○
Corrosion resistance	● ● ● ○ ○

Dimensions

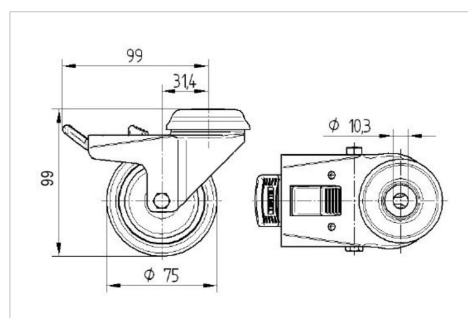

Structure & Mounting

